

SMT NUT and Standoff

- SMT full automatic reflux welding process can increase
- Production stability and production efficiency
- Welding for reinstatement can increase product reliability
- Reduce a damage risk of circuit caused during assembling

SMT SNAP IN LOCK

Patented.



Material and Finish

PIN :
3000 SERIES BRASS , TIN FINISH .
PLUG:
RUBBER

Panel Preparation

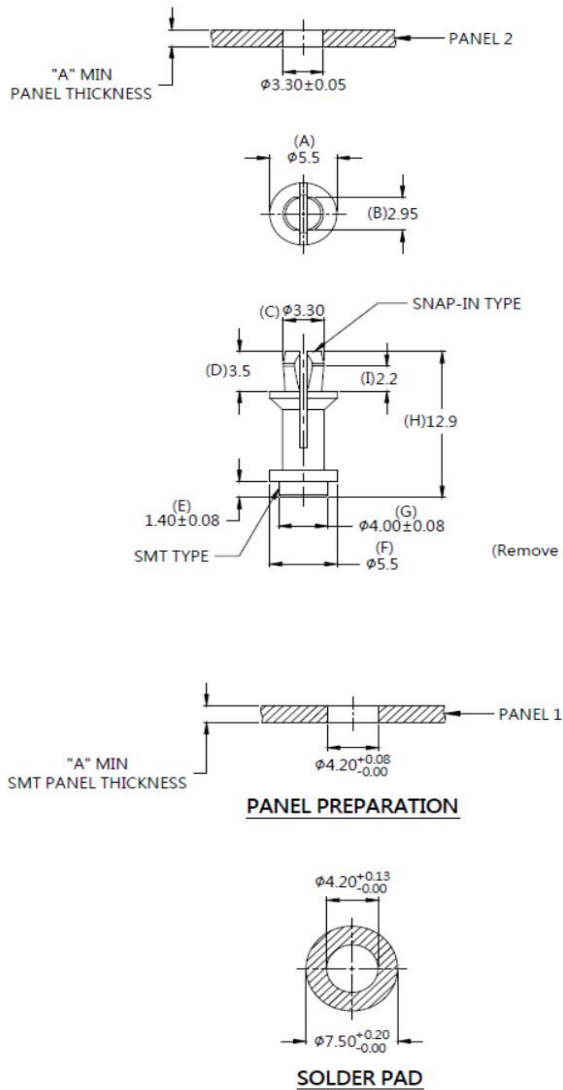

Installation

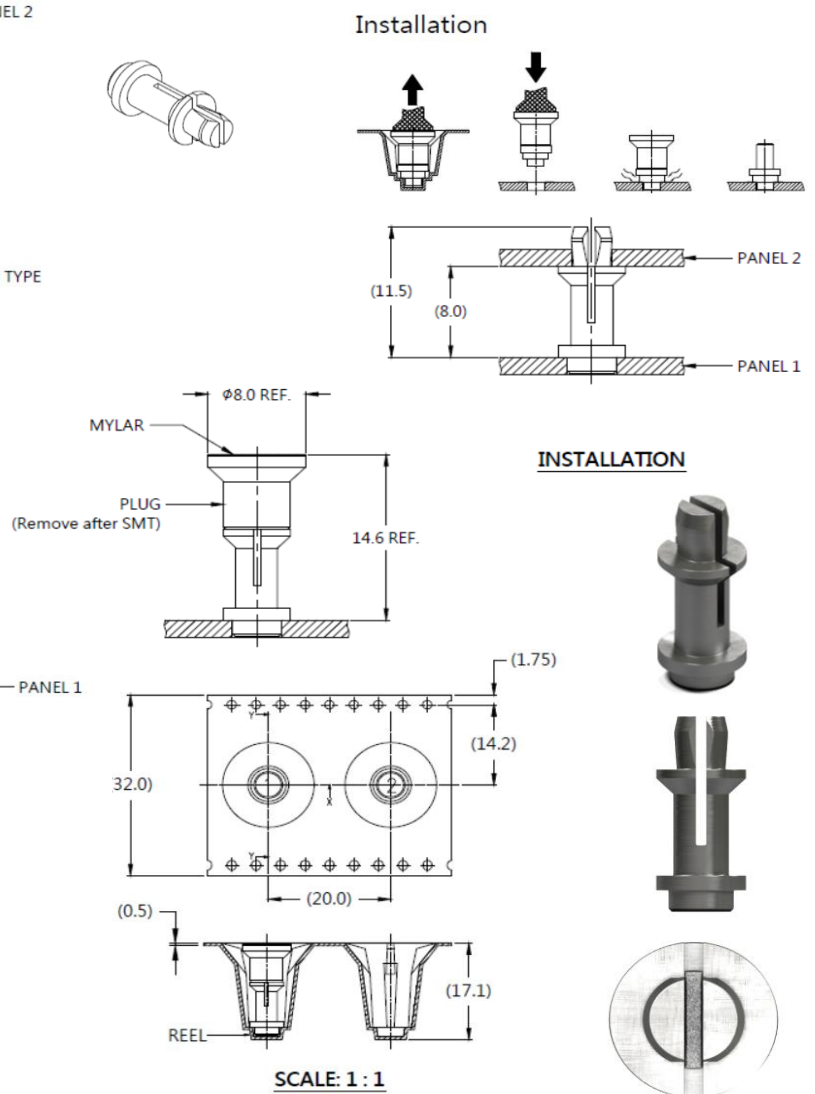

Dimensions (mm)

LENGTH "T"	PROJECTION		SMT PANEL THICKNESS		PANEL THICKNESS		DIMENSINOS	
	"P-1"	"P-2"	"A" MIN	"A" MAX	"A" MIN	"A" MAX	"L"	"B"
~	~	~	1.5	~	1.5	2.0	~	~